

GME Past Performance

Company Profile:

Founded in 2000, Great Magtech (Xiamen) Electric Co., Ltd.(GME) is a brand dedicated to offer a wide range of precast concrete products and construction components, We have successfully cooperated World Top 500 Companies, like Lafargeholcim. Our shutter magnets are now sold to all over the world, especially Middle East, Northern Europe, Southeast Asia and Oceania.

Our factory is in Ningbo, covering an area of 50000 square meters. The investment has reached RMB 170 million successively since its establishment. There are more than 200 professional and experienced staff, including 45+ R&D experts. Products already passed TS16949, ISO9001-2000, CE, RoHS and SGS guidelines.

Be in the light of the principle of "the quality and service first", the company built up a strict quality management system, such as APQP, FMEA, SPC, PPAP, MSA. We prides itself in delivering products and services that consistently take the business forward and provide clients with new, exciting innovations to meet the ever increasing demand for quality and value for money.



Product Certificate:

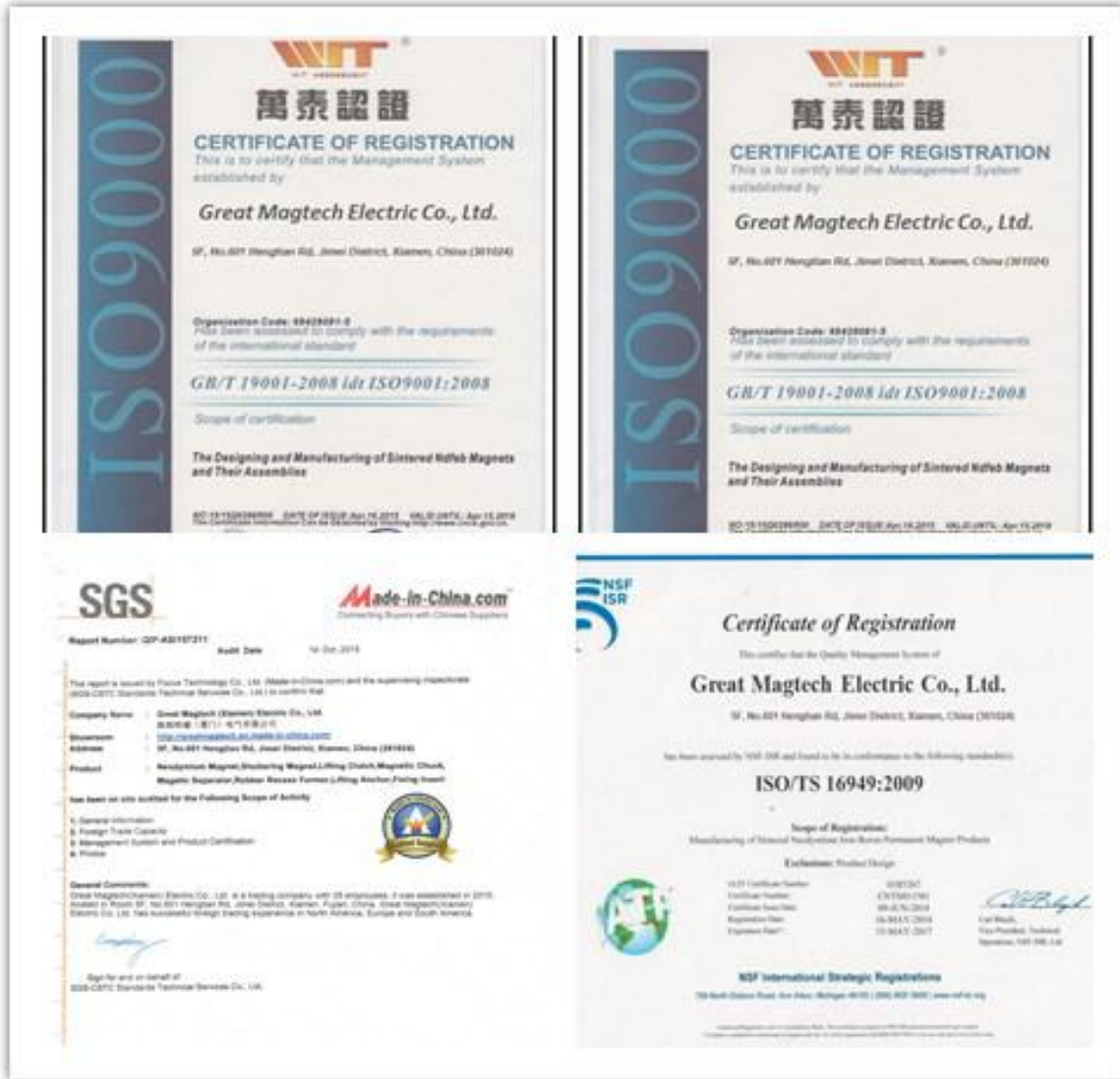

The image displays four certificates of registration. The top two are ISO 9001:2008 registration certificates issued by WIT (Wan Tai) to Great Magtech Electric Co., Ltd. for the scope of 'The Designing and Manufacturing of Sintered NdFeB Magnets and Their Assemblies'. The bottom two are ISO/TS 16949:2009 registration certificates issued by SGS and NSF/ISR to Great Magtech Electric Co., Ltd. for the scope of 'Manufacturing of Sintered Neodymium Iron-Boron Permanent Magnet Products'.

Testing Report:



测试报告
编号: QDN16090206GME_CN
日期: 2018-05-16
页码: 2 of 2

测试项目	试样类型	最大值 (μG)
结果-1	不锈钢加工试样	97.02
结果-2		98.52



样品照片
报告结束



ROHS Test Report
Shenzhen BCTC Technology Co., Ltd. Report No.: BCTC-150912319

Applicant: Great Magtech(Xiamen) Electric Co., Ltd.
Address: 5F, No.601 Hengtian Rd, Jimei District, Xiamen, China (361024)
Manufacturer: Great Magtech(Xiamen) Electric Co., Ltd.
Address: 5F, No.601 Hengtian Rd, Jimei District, Xiamen, China (361024)

Report on the submitted sample said to be NoFeB

Tested Component Description: Wire Loop Box
Model of the sample: N/A
Trademark: N/A
Sample received date: Sep. 25, 2018
Test completed date: Oct. 08, 2018
Test requested: With reference to Directive 2011/65/EU
1) To determine the Cadmium, Lead & Mercury Content in the submitted sample.
2) To determine the Hexavalent Chromium Content on the submitted sample.

Test method: 1) With reference to US EPA3052 and IEC 11154:CDV 62321 Method and EN 1122:2018. The sample was digested by acid. Analysis was performed by Inductively Coupled Argon Plasma - Atomic Emission Spectrometry (ICP-AES) or Atomic Absorption Spectrometry(AAS& Cold-Vapor-AA).
2) With reference to IEC11154:CDV 62321 Ed 1 Sec.8 for metallic (IEC 11154:CDV 62321 Ed 1 Sec.9 for nonmetallic) sample and then analyzed by using ICP-MS Spectrophotometry.
3) With reference to EPA Method 3540C/3550C and IEC 11154:CDV 62321 Ed 1 Sec.7. Analysis was performed by GC/MS or LCI/MS.
Please refer to next page.

Test result: Passed

Tested by: Casey Wang Inspected by: Daisy Zhang
Approved by: Casey Wang Date: Oct. 08, 2018

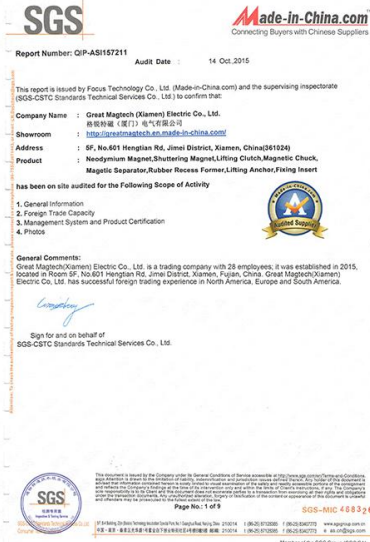

SGS Made-in-China.com
Report Number: QIP-AS1157211 Audit Date: 14 Oct. 2015

The report is issued by Focus Technology Co., Ltd. (Made-in-China.com) and the supervising inspectorate (SGS-CSTC Standards Technical Services Co., Ltd.) to confirm that:

Company Name: Great Magtech (Xiamen) Electric Co., Ltd.
Address: 5F, No.601 Hengtian Rd, Jimei District, Xiamen, China(361024)
Showroom: http://greatmagtech.en.made-in-china.com/
Product: Neodymium Magnet,Shuttering Magnet,Lifting Chain,Magnetic Chuck, Magnetic Separator,Rubber Roller,Former,Lifting anchor,Feeling Insert

has been on site audited for the Following Scope of Activity

1. General Information
2. Foreign Trade Capacity
3. Management System and Product Certification
4. Prices

General Comments: Great Magtech(Xiamen) Electric Co., Ltd. is a trading company with 28 employees, it was established in 2015, located in Room 5F, No.601 Hengtian Rd, Jimei District, Xiamen, Fujian, China. Great Magtech(Xiamen) Electric Co., Ltd. has successful foreign trading experience in North America, Europe and South America.

Sign for and on behalf of SGS-CSTC Standards Technical Services Co., Ltd.

Page No. 1 of 8
SGS-MSC 48838-B
Member of the SGS Group (ISSS SIA)

Production Equipment And Process:

What sets us apart from our competitors are our ideal magnetic solution, excellent quality, and great service.

With testing laboratory which equipped with the state-of-the-art measuring and testing devices, our QC dept. ensures ongoing development and maintenance of high quality standards and guarantees full compliance with customer requirements and all applicable regulations. (production equipment and process as below)

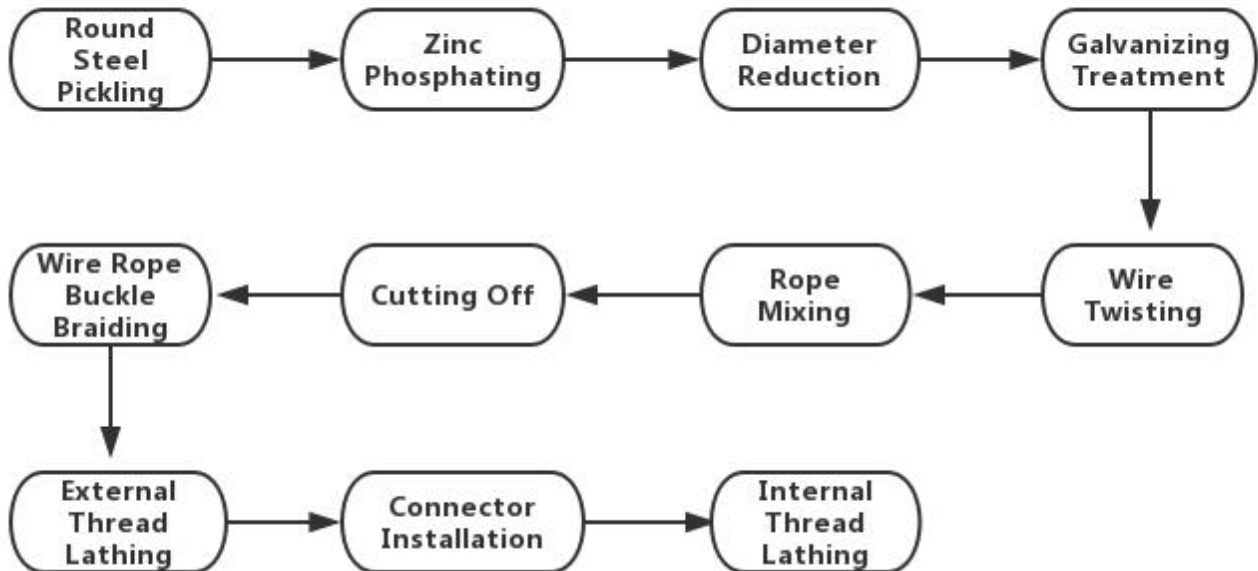

From the production of parts to the final product, the wire loop box requires 11 steps. (The specific production process depends on different equipment capabilities)

To assure the quality, we would conduct strict quality check in accordance with the industry standard. A special quality inspector is responsible for inspecting each process.

Past Project

Our company is about to be established for 20 years. During these two decades, we have the footprint of our products on all continents. In this fast innovation and development-oriented industry, we rely on solid product quality and strive to open up a path that belongs to us. The following product catalogue comes from our cooperation with customers in the Philippines. Three years ago, we started our first collaboration with this customer. Since then, we have become one of the stable suppliers of this customer in China.

Past Product List

Philippine Project	Code	Item	b (mm)	i (mm)	a (mm)	d (mm)	l (mm)	SL	Clip Color
	GME500S80	GME-S-80	80	220	25	3	212	80	black
	GME500S100	GME-S-100	80	220	25	3	212	100	black
	GME500S120	GME-S-120	80	220	25	3	212	120	black

Product Drawing

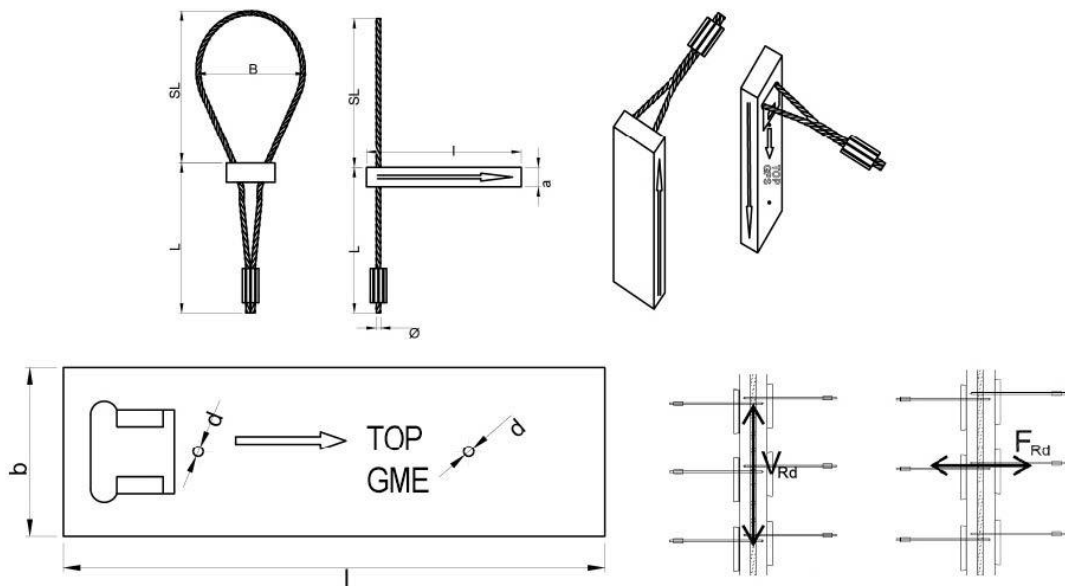

Packaging:

The quality of product packaging directly affects the quality of the product. Therefore, we have established a strict packaging management system:

- strict responsibility system
- inspection system for packaging quality
- scientific control statistical method



On Site Application



Why Choose Us?

As an reliable supplier from China, we have served numerous clients all over the world. We have been working with our customers for fifteen years. We have a comprehensive set of services, sales, and after-sales service. Not only that, We solemnly promise that our products have the following advantages:

1. Fix the concrete and steel bars by the cooperation of the steel wire rope and the connecting box, and ensure the stability and stability of the steel bars by the toughness of the steel wire rope;
2. By accommodating the middle section of the wire rope in the accommodating cavity, it is ensured that the middle section of the wire rope does not stick to the concrete;
3. Fix the wire rope by pushing the fixing piece into the pressing piece, which is stable and convenient.

Relative Project (with)

